



INVERTER GENERATOR 2300/3500W 230V 4-STROKE ENGINE

MODEL NO: **GI2300, GI3500**

Thank you for purchasing a Sealey product. Manufactured to a high standard, this product will, if used according to these instructions, and properly maintained, give you years of trouble free performance.

IMPORTANT: PLEASE READ THESE INSTRUCTIONS CAREFULLY. NOTE THE SAFE OPERATIONAL REQUIREMENTS, WARNINGS & CAUTIONS. USE THE PRODUCT CORRECTLY AND WITH CARE FOR THE PURPOSE FOR WHICH IT IS INTENDED. FAILURE TO DO SO MAY CAUSE DAMAGE AND/OR PERSONAL INJURY AND WILL INVALIDATE THE WARRANTY. KEEP THESE INSTRUCTIONS SAFE FOR FUTURE USE.



Refer to instructions



Electrical shock hazard



Hot surfaces



Do not cover



Only for use in well-ventilated areas



Switch off the engine Before refuelling

1. SAFETY

- WARNING! The Generator is shipped without oil. Check oil level and fill as required before use.**
- WARNING! Ensure any Health & Safety, Government, or local authority regulations are adhered to when using this equipment.**
- ✓ Familiarise yourself with the application and limitations, as well as the potential hazards, of the generator.
- ✓ Maintain the generator in good condition (use an authorised service agent). Replace or repair damaged parts. Use genuine parts only. Unauthorised parts may be dangerous and will invalidate the warranty.
- ✓ This generator is designed and manufactured for specific applications. **DO NOT** attempt to modify the unit or use it for any application for which it is not designed. If you have any questions regarding the application of the unit please contact your local Sealey stockist.
- WARNING! DO NOT** exceed the Wattage/Amperage capacity of the generator. Add rated wattage of all devices intended for connection at any one time, the total must not exceed rated wattage of generator (see specifications).
- WARNING!** Generator exhaust gases contain deadly carbon monoxide which must not be inhaled. Always allow sufficient ventilation.
- WARNING!** If you decide to use an Earth Leakage Circuit Breaker (also referred to as an RCD or Ground Fault Circuit Interrupter), it is imperative that the neutral end of the power winding is connected to the frame of the generator set and that the earth lug on the frame is connected with a low impedance connector to the local earth via an earth spike or local protective earth conductor. This connection should only be attempted by a qualified electrician, after first having consulted your local stockist.#
- WARNING!** Only use in well-ventilated areas to reduce risk of suffocation.
- ▲ **DANGER!** If this unit is used for back-up power in the event of a commercial power failure, the following steps must be taken. Before connecting the generator to the electrical system, open the main circuit breaker to isolate the generator and system from the commercial electric supply. Failure to do this may result in damage to the generator and may result in serious injury or fatality, due to a back-feed of electrical energy.
- ▲ **DANGER!** The generator produces a very powerful voltage that can cause a severe electrical shock. Avoid contact with bare wires, terminals etc. Never allow any unqualified person to operate or service the generator.
- WARNING!** Petrol is highly flammable and petrol vapour is explosive. **Do not** permit smoking, naked flames, sparks or heat in the vicinity while handling petrol. Avoid spilling petrol onto a hot engine. Comply with all laws regulating storage and handling of fuels.
- WARNING!** Risk of burns. **DO NOT** touch the exhaust system or the drive unit.
- WARNING! NEVER** refuel when the engine is running or when the engine is hot. Allow cool down time.
- ✓ Operate the generator only on level surfaces (maximum allowable tilt is 10°) and where it will not be exposed to excessive moisture, dirt or corrosive vapours or be in the proximity of combustible material (flammable liquids, solids or gases).
- × **DO NOT** tip or change the generator's position whilst it is operating.
- ✓ Remove ill fitting clothing, ties, watches, rings and other loose jewellery and contain long hair. Wear appropriate protective clothing.
- ✓ Keep non-essential persons and children away from the working area.
- WARNING!** Never start or stop the generator while electrical loads are connected. Start the engine, let it stabilise, then connect the electrical load. To stop engine, disconnect the electrical load and let engine stabilise before switching off.
- WARNING! DO NOT** use worn, bare, frayed or otherwise damaged electrical cables with the generator. Electric shock may occur.
- × **DO NOT** use the generator for any purpose other than that for which it is designed.
- × **DO NOT** operate the generator if any parts are missing or damaged, as this may cause failure and/or personal injury.
- × **DO NOT** over-fill fuel tank. Always leave room for fuel to expand.
- × **DO NOT** operate in the rain.
- ▲ **DANGER! DO NOT** tamper with the engine governed speed setting. Higher operating speeds are dangerous and increase the risk of personal injury and/or equipment damage. The generator supplies the correct rated frequencies and voltage only when running at the correct governed speed. Incorrect frequency and/or voltage can damage some connected electrical loads. Operating at excessively low speeds may result in shortened engine life. Over-speeding will invalidate the warranty.
- × **DO NOT** operate the generator when you are tired, or under the influence of alcohol, drugs or intoxicating medication.
- × **DO NOT** store generator with fuel in tank where petrol vapours might reach an open flame or spark.
- ✓ The generator must be grounded with a good quality insulated conductor.
- ✓ Keep vents free from dirt etc.
- ✓ If supplying electronic equipment, or in an area where electronic equipment is being used, keep the generator a sufficient distance away to prevent electrical noise from the engine.

2. INTRODUCTION

Heavy-duty frame provides full protection and incorporates carry handles for portability. Inverter generator suitable for running sensitive electrical equipment. Produces a clean AC current to match the load. Long running time of up to 8 hours on a full tank of fuel. Fitted with two 230V 13 Amp sockets. Increased fuel efficiency compared to standard generators. Features oil warning light, overload indicator and sight glass to monitor fuel level.

3. SPECIFICATION

Model No.....	GI2300.....	GI3500
Motor Power.....	2.3KW.....	3.5KW
Motor Type	4-Stroke Petrol.....	4-Stroke Petrol
Output	230V-50Hz.....	230V-50Hz
Current Rating.....	8.3A.....	15.2A
Continuous Power Rating.....	2000W.....	3200W
Max. Power Rating.....	2300W.....	3500W
Fuel Tank Capacity.....	13ltr.....	13ltr
Max. Running Time	13Hr.....	8hr
Noise Rating	95dB(A).....	95dB(A)
Noise pressure level.....	74db.....	74db
Dry Weight	35.1Kg.....	35.5Kg
Dimension (WxDxH).....	440x520x470mm.....	440x520x470mm
Fuel.....	Unleaded Petrol.....	Unleaded Petrol

4. OPERATION

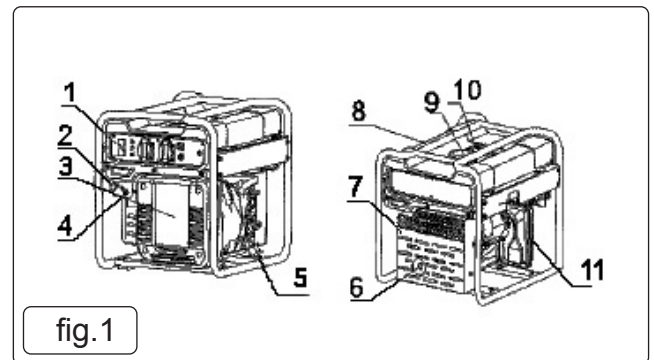

- 4.1. Description fig.1.
1. Control panel
 2. Choke Knob
 3. Inverter cover
 4. Fuel cock knob
 5. Recoil starter
 6. Muffler
 7. Muffler cover
 8. Fuel tank
 9. Fuel tank cap
 10. Fuel gauge
 11. Air filter

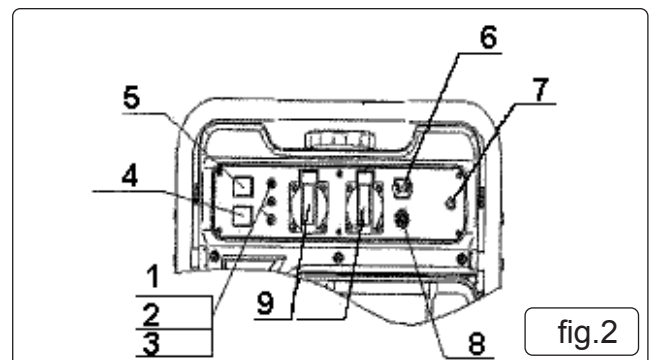

- 4.2. Control Panel fig.2.
1. Oil warning light
 2. AC pilot light
 3. Overload indicator light
 4. Economy control switch
 5. Engine switch
 6. DC socket
 7. Earth terminal
 8. DC protector
 9. AC socket



4.3. Control Functions

- 4.3.1. Engine Switch
- Ignition circuit is switched off 
- Ignition circuit is switched on 

- 4.3.2. Oil warning light (yellow)
- When the oil level falls below the lower level, the oil warning light fig.3.1. comes on the engine then stops automatically. Until the oil is refilled the engine will not start. If the engine stalls or does not start, turn the engine switch to "ON" and then pull recoil starter cord. If the oil warning light flickers for a few seconds, there is insufficient oil. top up oil and restart.

- 4.3.3. Overload indicator light (red)
- The overload indicator light (3) comes on when an overload is detected, the inverter control unit overheats, or the AC output voltages rise. The AC protector will trip and stop power generation in order to protect the generator. The AC pilot light (Green) will go off and the overload indicator light (red) will stay on. The power generation will stop. When this happens proceed as follows. Turn off any connected electric devices and stop the engine. Reduce the total wattage of connected appliance into the rated output.

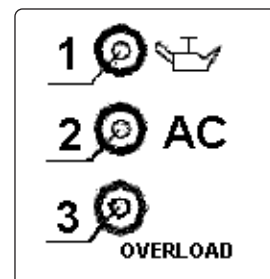

fig.3

Check for blockages in the cooling air inlet and around the control unit. If any blockages are found, clear them. After checking, restart the engine. Note: The overload indicator light may come on for a few seconds when the generator starts. This is normal for devices that require a large starting current. This is not a malfunction.

4.3.4. AC pilot light (green)

The AC pilot light fig.3.(2) comes on when the engine starts and produces power.

4.4. DC Protector

4.4.1. The DC protector turns to "OFF" fig.4.(2) automatically when electric device being connected to the generator is operating at a higher current than the max stated in specifications.

4.4.2. To turn the power on press the button to the "ON" (1) position.

N.B. Reduce the load before restarting.

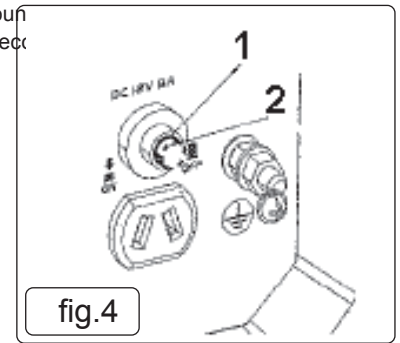

fig.4

4.5. Economy control switch (ECS) fig.5

4.5.1. "ON" (1)

When the ECS switch is turned to "ON" the economy control unit controls the engine speed according to the connected load. The results are better fuel consumption and less noise.

4.5.2. "OFF" (2)

When the ECS switch is turned to "OFF" the engine runs at the rated speed (3600r/min) regardless of whether a load is connected or not.

4.5.3. The ECS must be turned to "OFF" when using electric devices that require a larger starting current.

4.6. Earth terminal fig.4

4.6.1. Earth terminal fig.5.(1) connects the earth line to prevent electric shock.

N.B If the device is earthed the generator must be earthed.

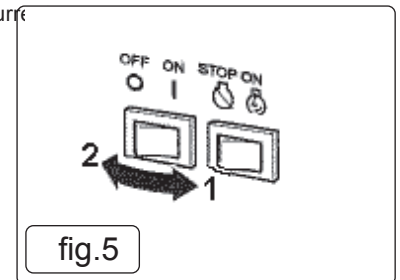

fig.5

4.7. FUEL

4.7.1. Do Not overfill the fuel tank, otherwise it may overflow when the fuel warms up and expands.

4.7.2. After filling ensure tank cap is tightened securely.

4.7.3. Wipe off any fuel that has been spilled.

4.7.4. Use only unleaded petrol.

4.7.5. Remove the fuel tank cap fig.6.

4.7.6. Pour in fuel up to the red line fig.7. (1)

4.7.7. Fuel level fig.8. (2)

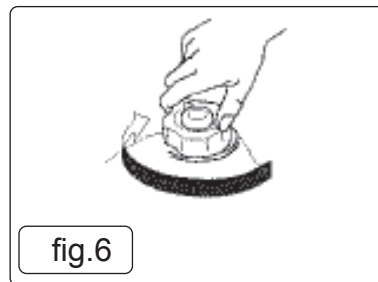

fig.6

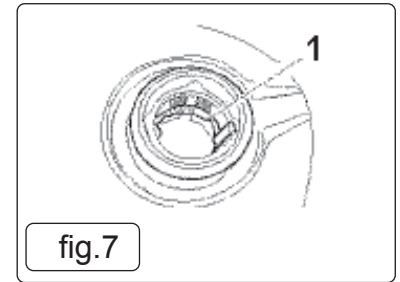

fig.7

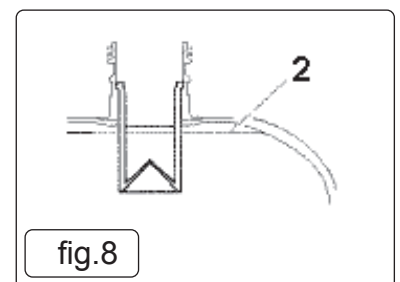

fig.8

4.8. Engine oil

N.B. The generator has been transported without engine oil. Do not start the engine until filled with sufficient engine oil.

4.8.1. Place the generator on a level surface.

4.8.2. Remove the oil gauge.

4.8.3. Fill the generator with the amount of engine oil specified.

4.8.4. Replace oil gauge fig.9.

4.8.5. Recommended engine oil SAE SJ 15W-40.

4.8.6. Engine oil capacity 0.45L.

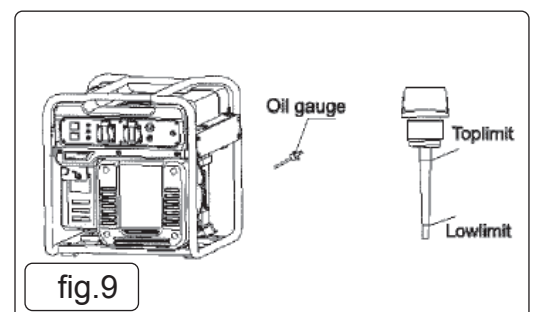

fig.9

4.9. Standard atmospheric conditions

Ambient temperature 25°C

Barometric pressure 100kPa

Relative humidity 30%

The output of the generator will vary dependant on the deviation from the standard conditions.

4.10. Starting the engine

- 4.10.1. Turn the ECS switch to "OFF" fig.10.
- 4.10.2. Turn the fuel cock knob to "ON" fig.11.
- 4.10.3. Turn the engine switch to "ON" fig.12.
- 4.10.4. Pull the choke knob fully out fig.13. (The choke is not required to start a warm engine.)
- 4.10.5. Grasp the carrying handle to prevent the generator from falling over. Pull slowly on the recoil starter until it is engaged, then pull it briskly fig.14.
- 4.10.6. After the engine starts, let the engine warm up until the engine does not stop when the choke knob is returned to the original position fig.15.

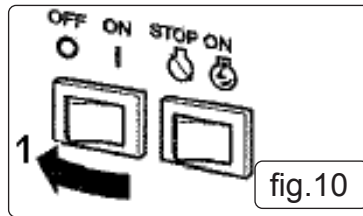

fig.10

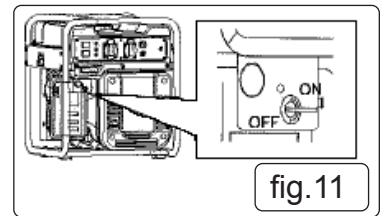

fig.11

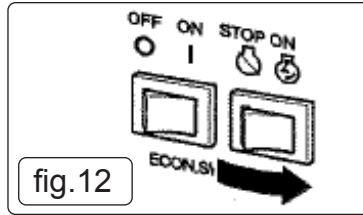

fig.12

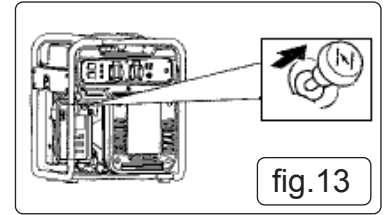

fig.13

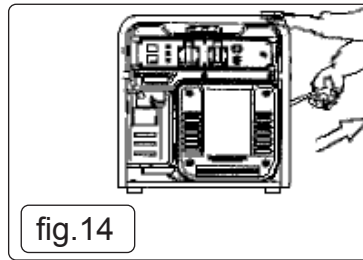

fig.14

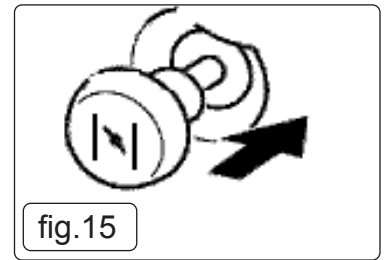

fig.15

4.11. Stopping the engine

- 4.11.1. Turn off any electric devices.
- 4.11.2. Turn the ECS to "OFF"
- 4.11.3. Disconnect any electric devices.
- 4.11.4. Turn the engine switch to "STOP"

4.12. Alternating Current (AC) connection

- 4.12.1. Turn off all electrical devices before plugging them in.
- 4.12.2. Ensure total load is within generator rated output.
- 4.12.3. Ensure generator is earthed if any of the electrical devices are earthed.
- 4.12.4. Start the engine.
- 4.12.5. Turn the ECS to "ON".
- 4.12.6. Plug device into socket and make sure AC pilot light is on.
- 4.12.7. Turn on electrical device.

4.13. Battery Charging



Wear eye protection



Wear protective gloves



Electrical shock hazard



Warning corrosive substance



Keep away from sources of ignition

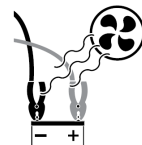

Use in well ventilated areas



Keep in dry area protect from rain

The generator DC rated voltage is 12V.

Before starting to charge the battery, make sure that the DC protector is turned on.

- 4.13.2. Start the engine.
- 4.13.3. Connect the red battery charger lead to the positive (+) battery terminal.
- 4.13.4. Connect the black battery charger lead to the negative (-) battery terminal.
- 4.13.5. Turn the ECS to "OFF" to start battery charging.
- 4.13.6. Charge the battery using the correct procedure laid down by the battery manufacturer's instructions. Follow the instructions to determine the end of battery charging, this may include measurements of specific gravity at regular intervals. **DO NOT** over charge battery.
 - ❑ **WARNING!** "Modern vehicles contain extensive electronic systems. You are required to check with the vehicle Manufacturer, for any specific instructions regarding the use of this type of equipment on each vehicle. No liability will be accepted for damage / injury, where this product is not used in accordance with all instructions."
- 4.13.7. The DC protector turns off automatically if current is above the generator rating. To restart charging the battery, turn the DC protector on. If the protector turns off again, stop charging the battery immediately.

5. MAINTENANCE

N.B. Stop the engine before servicing. Put the engine on a level surface and remove the spark plug cap to prevent engine from starting.

5.1. The engine must be properly maintained to ensure its operation be safe and economical.

In order to keep the engine in good working condition, it must be periodically serviced. the following maintenance schedule and routine inspection procedures must be carefully followed:

Items		Each Time	First month or first 20hrs of operation.	Thereafter every 3 months or every 50hrs of operation	Every year or every 100hrs of operation.
Engine Oil	Check-Refill	✓			
	Replace		✓	✓	
Reduction gear Oil (if equipped)	Oil Level Check	✓			
	Replace		✓	✓	
Air filter elements	Check	✓			
	Clean		✓		
	Replace			✓	
Deposit Cup (if equipped)	Clean				✓
Spark Plug	Check-adjust				✓*
Spark arrester	Clean			✓	
Idling (if equipped)**	Check-adjust				✓
Valve clearance**	Check-adjust				✓
Fuel tank & fuel filter**	Clean				✓
Fuel Line	Check	Every 2 years (change if necessary)			
Cylinder head ,piston	Clean up carbon	<225cc, Every 125hrs ≤225cc, Every 250hrs			

* These items should be replaced if replacement is need.
** The installation and major repair work shall be carried out by specifically trained personnel.

5.2. If the engine frequently works under high temperature or heavy load, change the oil every 25 hours.

5.3. If the engine works in a dusty or other environment clean the air filter element every 10hrs, if necessary, change the air filter.

5.4. Spark plug inspection fig.16.

5.4.1. Remove the cap and spark plug cap, insert the tool through the hole from the outside of the cover.

5.4.2. Insert the bar into the tool and turn it anti-clockwise to remove the spark plug.

5.4.3. Check for discolouration and remove the carbon. The porcelain insulator around the centre electrode of the spark plug should be a medium-to-light tan colour.

5.4.4. Check the spark plug type and gap. adjust as required.

Standard Spark Plug: E6TC/E6RTC.

Spark Plug Gap:0.6-0.7mm

Spark Plug Torque: 20Nm

5.5. Carburettor adjustment

Adjustment should be left to authorized stockist with knowledge, data and equipment.

5.6. Engine oil replacement

Do Not drain the engine oil immediately after stopping the engine, the oil will be hot and should be handled with care.

5.6.1. Place the generator on a level surface and warm up the engine for several minutes. Stop the engine and turn off fuel switch knob.

5.6.2. Remove the oil filler cap.

5.6.3. Place an oil pan under the engine. Tilt the generator to drain the oil.

5.6.4. Put the generator on a flat surface.

5.6.5. Add engine oil to the top limit level.

Recommended engine oil: SAE SJ 15W-40

Recommended engine oil grade: API Service SE type or higher

Engine oil quantity: 0.35L

5.6.6. Wipe away any spilled oil, be sure no foreign material enters the crankcase

5.6.7. Install the oil filler cap/cover

5.7. Air Filter

5.7.1. Remove the air filter cover.

5.7.2. Remove the foam element.

5.7.3. Wash the foam element in solvent and dry it.

5.7.4. Oil the foam element and squeeze out excess oil.

5.7.5. The foam element should be wet but not dripping.

5.7.6. Insert the foam element into the air filter case.

5.7.7. Install the air filter case cover in position and tighten screws.

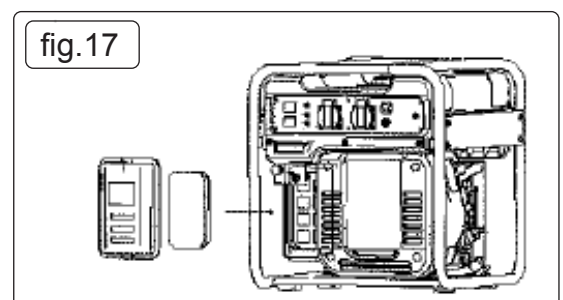
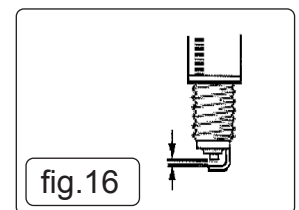

5.8. Muffler screen and spark arrester.

- ❑ **WARNING!** The engine and muffler will be very hot after the engine has been run. Avoid touching the engine and muffler while they are still hot.
- 5.8.1. Loosen the cover and remove.
- 5.8.2. Loosen the bolts then remove the muffler cap, the muffler screen and spark arrester.
- 5.8.3. Clean the carbon deposits on the muffler screen and spark arrester using a wire brush. Brush gently to avoid damage to the component.
- 5.8.4. Check the muffler screen and spark arrester. Replace if damaged.
- 5.8.5. Install the spark arrester.
- 5.8.6. Install the muffler screen and the muffler cap.
- 5.8.7. Install the cover and tighten the screws.

5.9. Fuel tank filter

- 5.9.1. Remove the tank cap and filter.
- 5.9.2. Clean the filter with petrol.
- 5.9.3. Wipe the filter and install it.
- 5.9.4. Replace the fuel tank cap. Be sure the fuel tank cap is tightened securely.

5.10. Fuel Filter

- 5.10.1. The fuel filter is located in the fuel pipe leading from the fuel tank to the carburettor.
- 5.10.2. Drain fuel from fuel tank.
- 5.10.3. Squeeze the pipe clamps and remove the filter.
- 5.10.4. Replace the filter.
- 5.10.5. Attach the fuel pipes and re-clamp.
- 5.10.6. Check for any fuel leaks.

6. STORAGE

Long term storage of the generator will require preventive procedures to guard against deterioration.

- 6.1. Turn the engine switch to "STOP".
- 6.2. Remove fuel tank cap and filter.
- 6.3. Extract the fuel from the tank into an approved fuel container. Replace the fuel filter and cap.
- 6.4. Wipe off any spilt fuel.
- 6.5. Start the engine and leave it to stop. (approx 20 min)
- 6.6. Drain the fuel from the carburettor, by removing screw on the float chamber. Replace screw.
- 6.7. Turn the engine switch to "STOP".
- 6.8. Remove the spark plug, pour about one table-spoon of SAE 10W-30 into spark plug hole. Using the recoil starter turn over the engine to coat the cylinder walls with oil.
- 6.9. Replace spark plug, pull the recoil starter until you feel compression. Then stop pulling. (This prevents the cylinder and valves from rusting)
- 6.10. Clean exterior of the generator with a dry cloth. Store the generator in a dry, well-ventilated child proof area.

7. TROUBLESHOOTING

- 7.1. Fuel System:- Check fuel in tank, vent knob and fuel tap to "ON"
Check fuel filter, carburettor, clean as required.
- 7.2. Oil System:- Check oil level, fill as required.
- 7.3. Electrical system:- Check/Clean spark plug
Faulty ignition system, Consult our authorized stockist.
- 7.4. No power produced:- Press the DC protector to "ON"
The AC pilot light (green) goes off, Stop the engine and then restart.



ENVIRONMENT PROTECTION

Recycle unwanted materials instead of disposing of them as waste. All tools, accessories and packaging should be sorted, taken to a recycling centre and disposed of in a manner which is compatible with the environment. When the product becomes completely unserviceable and requires disposal, drain any fluids (if applicable) into approved containers and dispose of the product and fluids according to local regulations.



WEEE REGULATIONS

Dispose of this product at the end of its working life in compliance with the EU Directive on Waste Electrical and Electronic Equipment (WEEE). When the product is no longer required, it must be disposed of in an environmentally protective way. Contact your local solid waste authority for recycling information.

Note: It is our policy to continually improve products and as such we reserve the right to alter data, specifications and component parts without prior notice.

Important: No Liability is accepted for incorrect use of this product.

Warranty: Guarantee is 12 months from purchase date, proof of which is required for any claim.



REGISTER YOUR PURCHASE HERE

Jack Sealey Ltd t/a Sealey Group, Kempson Way, Suffolk Business Park, Bury St Edmunds, Suffolk, IP32 7AR UK
Jack Sealey (EU) Ltd t/a Sealey Group, Farney Street, Carrickmacross, Co. Monaghan, A81 PK68 Ireland
Tel: 01284 757500 • **Email:** sales@sealey.co.uk • **Web:** www.sealey.co.uk